



RB22 Barrier

Specification Sheet
RBS160000

07/04/26

safesite[®]
F A C I L I T I E S

safesitefacilities.co.uk



Heavy duty crash tested RB22 Barrier

The versatility and stability that the barrier offers together with its ease of use and transportation secures its unrivalled position in the market.

The RB22 barrier is extremely versatile and can be used on a multitude of sites and in conjunction with many different products. These water-filled barriers are crashed tested and designed to withstand impacts from errant vehicles travelling up to 50 mph. RB22s can be installed without the need for specialist equipment and can be set up to navigate sweeping curves and 90° angles.

These barriers are ideally suited as borders for temporary roadworks, or locations where the public and workers need to be protected from moving vehicles. When filled, these HDPE barriers weigh over half a tonne, and are able to absorb moderate speeds and deflect vehicles away. The RB22 barriers interlock with steel pins and screw together with flat steel plates to add strength and stability.

When empty the barriers weigh a modest 60kg. The barriers are easy to empty and feature a small plug at the base of the unit for drainage. When filling barrier, fill to the first indentation of the barrier to get the maximum weight of 600kg.

RB22 Barrier Specification

Description	Size (mm)	Working Width (mm)	Weight (kg)	Weight Filled (kg)
RBS160000 – RB22 Barrier – Red	H800 x W2190 x D500	2000	60	600
RBSS160010 – RB22 Barrier – White	H800 x W190 x D500	2000	60	600
RBSS160200 – RB22 Side Plate	H100 x W315 x D9	-	1.7	-
RBSS160250 – RB22 Connecting Pin	H800 x D76.2	-	4	-

Key Features

- Tested and proven compliance with the following British Standards: BS EN1317 – NI 50 MPH test
- Minimal supplementary parts to ensure ease of installation
- Can be securely stacked, stored, and transported
- Compatible with a range of mesh and hoarding panel systems
- Manufactured from prime UV stabilised polyethylene
- Compatible with a range of vehicle and pedestrian gates
- Corporate colours and name plating
- Wide forklift slots at base

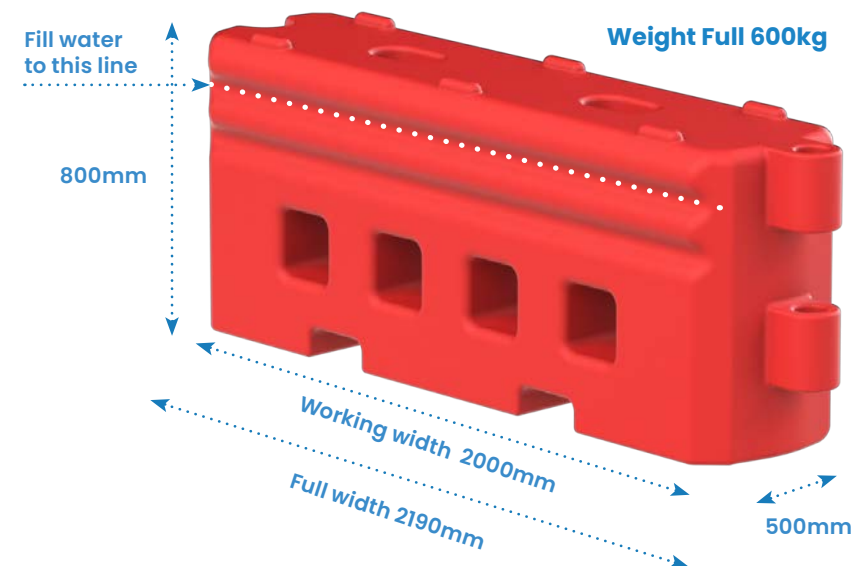

Please read on for a detailed illustration of the large range of products that can be used with the RB22 Barrier including mesh and hoarding.



RB22 Barrier with hoarding

Hoarding is an excellent way to add privacy and protection quickly and easily.

The RB22 can be used as a solid, above-ground base onto which you can fit hoarding panels. The panels slot easily into the ends of the barriers and are fixed in place with steel pins.



Hoarding & Add-On Specifications

Description	Size (mm)	Overall Height (mm)	Weight (kg)
RBS160400 - RB22 Connection Post	H1870 x W175 x D76.2	-	9
RBSS160300 - RB22 Hoarding Panel	H1400 x W1863 x D40	2255	25
RBSS160700 - RB22 Infill Panel	H1360 x W270 x D40	-	5
RBSS160360 - RB22 Mesh fence add-on	H620 x W1860 x D38	2875	8

Key Features

- Wind resistance of up to 44 mph
- Robust, temporary hoarding solution
- Colour options available

Hoarding panels



Hoarding infill panel



Please note: Adding infill panels will change the wind loading capabilities



RB22 Barrier with mesh fence panels

Our anti-climb mesh fence panels allow for professional, obscured view of your site whilst keeping intruders out. When fitted to the RB22, this above ground, stable solution can with stand wind speeds of up to 77.8mph.

The mesh panels can be supplied in a powder coated or galvanised finish. As with the hoarding panels, the mesh panels are fixed in place with a vertical pin and the barriers are screwed together using a metal fixing plate.

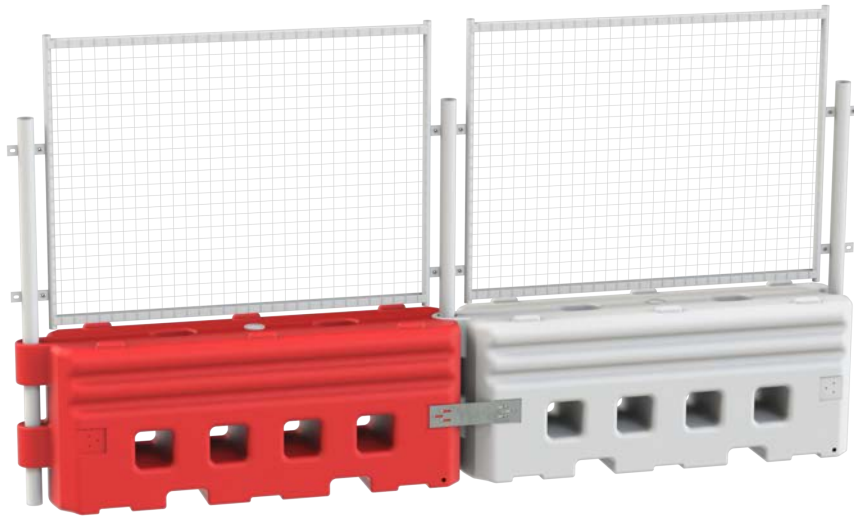

Mesh Fence & Add-On Specifications

Description	Size (mm)	Overall Height (mm)	Weight (kg)
RBS160400 - RB22 Connection Post	H1870 x W175 x D76.2	-	9
RBS160320 - RB22 Mesh Panel	H1400 x W1863 x D40	2255	8.7
RBS160360 - RB22 Mesh Fence Add-on	H620 x W1860 x D40	2875	8

Key Features

- Light and easy to handle
- Can be easily stacked, stored, and transported - 25 panels fit on to a single pallet
- Quick installation
- Wind resistance of up to 77.8 mph
- Colour options available
- Fence pole weight is just 10.2 kg

Mesh fence panels



Angled mesh panel





RB22 Barrier with hoarding & mesh solution

The combined hoarding and mesh panel solution offers the best of both worlds. You can obscure view of any untidiness or valuables, as well as allow for natural daylight on the site.

This option demonstrates how truly versatile the RB22 Barriers and panel options can be. Despite being comprised of two elements, the panel is easy to install and forms a single unit. You can also extend the overall height of the solution with the simple addition of a small mesh fence panel. The combination of the mesh and solid hoarding panel results in a total wind resistance of 60 mph.



Hoarding / Mesh Fence & Add-On Specifications

Description	Size (mm)	Overall Height (mm)	Weight (kg)
RBS160400 - RB22 Connection Post	H1870 x W175 x D76.2	-	9
RBS160340 - RB22 Hoarding / Mesh Panel	H1400 x W1863 x D40	2255	17
RBS160360 - RB22 Mesh Fence Add-on	H620 x W1860 x D40	2875	8

Key Features

- Light and easy to handle
- Versatile and interchangeable with other elements
- Can be easily stacked, stored, and transported - 25 panels fit on to a single pallet
- Quick installation
- Anti-climb mesh
- Wind resistance of up to 60 mph
- Colour options available
- Fence pole weight is just 10.2 kg

Half hoarding & fence next to vehicle gate



Half hoarding & half fence panel





RB22 Barrier – Vehicle & pedestrian gates

It is possible to install both a vehicle and pedestrian access point in our RB22 Barrier system. With the simple addition of an adaption pole, can be used to fix a range of gate sizes and types to the RB22 system.

Just as we can offer with the perimeter solution, we can offer steel hoarding, mesh panels and hybrid (mesh/hoarding panels), to suit your site whatever the location, weather, or nature of your site needs.

The gates are secured in position using rubber feet which are highly durable and purpose-built for outdoor sites including muddy and uneven surfaces. The simple and easy installation of the gates means that they are quick to install, secure and straight-forward to update.

Below we have featured a few illustrations of the options available to you, as well as a table with all sizes and dimensions. You may also find our range of CCTV, lighting, and security solutions valuable in conjunction with these products.

RB22 Pedestrian Gate Accessories Specifications

Description	Size (mm)	Weight (kg)
RBS160905 – Adaption Pole	H2000 x D40	2
RBS160915 – Adaption Pole Hoarding	H2000 x D40	4
TFS100605 – Rubber Fence Feet	120	13.5

Hoarding Gates

When using Hoarding gates the Adaption pole should be switched out for the more robust Adaption pole (RBS160915 RB22 Gate Adaption Pole For Hoarding Gates – White). This thicker pole will reduce the risk of bending in high winds.





RB22 Pedestrian Walkthrough Barrier with Sprung Gate

The RB22 Pedestrian Gate offers quick and hassle-free installation; simply remove one of the RB22 water-filled barriers and slot the gate into place, making it ideal for temporary or rapidly changing site requirements.

This pedestrian access solution is perfectly suited for construction sites, combining robust durability with practical design. Its fully galvanised frame, finished in high-visibility red powder coating, offers superior resistance to corrosion, and harsh weather conditions.

Designed for compatibility with RB22 Crash Barriers, it ensures secure and seamless integration into existing site safety systems. The addition of a rubber dampening pad helps minimise vibration and noise, enhancing longevity and durability. A simple, replaceable spring mechanism further supports low-maintenance operation and long-term reliability.



Gate installed



Rubber dampening pad

RB22 Sprung Gate Specification

Description	Size (mm)	Weight (kg)
RBS160995 - RB22 Sprung Gate	H2250 x W2123 x D40	29

Key Features

- Ideal for construction site pedestrian access
- Durable fully galvanised and red powder coated finish
- Designed to work with RB22 Crash Barriers barriers
- Simple installation by removing just one RB22 barrier
- Maintains seamless integration with existing RB22 barrier blocks
- Rubber dampening pad
- Easy replaceable spring mechanism

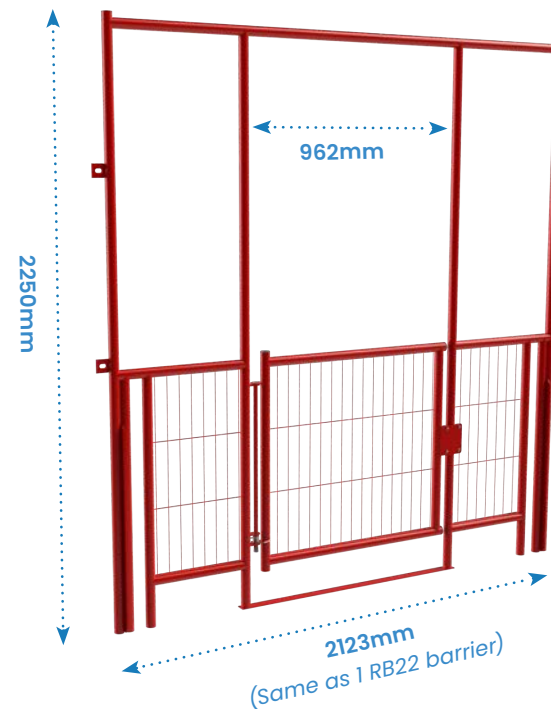



End and corner sections

In addition to its versatility in terms of fence and panel products, the RB22 Barriers can also be used to navigate sweeping corners and 90° angles.

The RB22 barrier's design and strength when filled, means they're ideal for use on racetracks and highways as a substantial traffic safety solution.

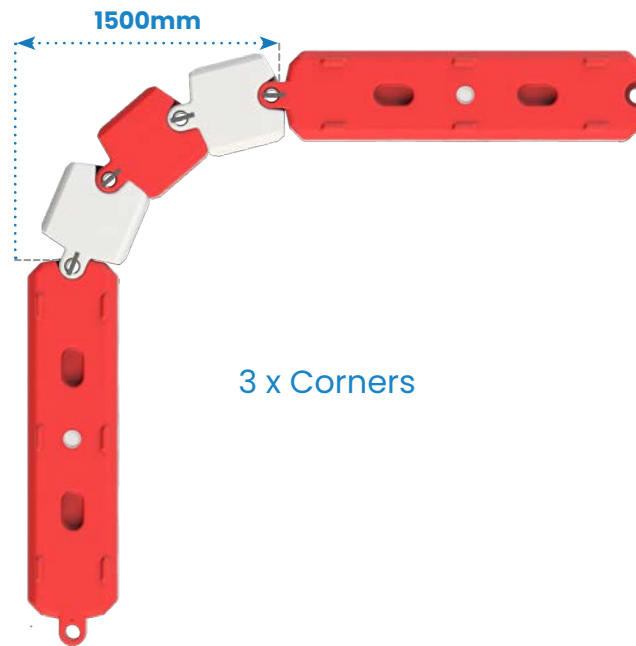

3 x Corners

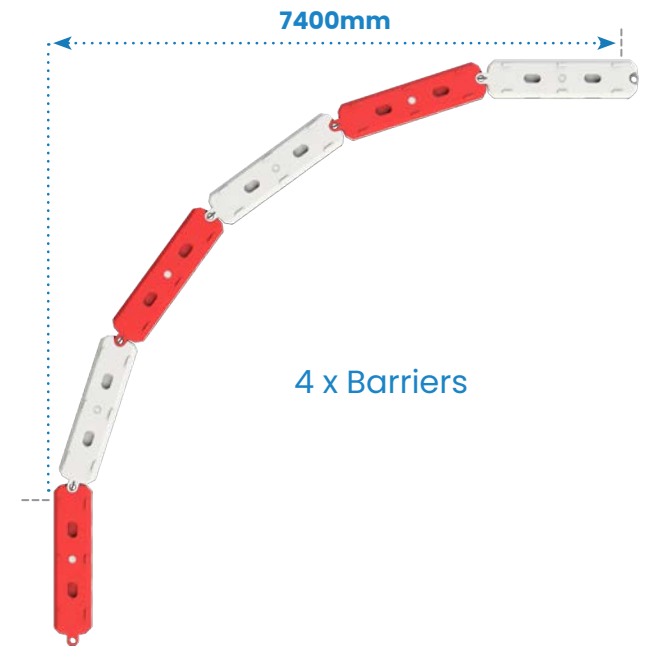

4 x Barriers

RB22 Ends & Corner Section Specifications

Description	Size (mm)	Weight (kg)
RBS160070 - RB22 End Stop - Red	H800 x W680 x D500	12
RBS160080 - RB22 End Stop - White	H800 x W680 x D500	12
RBS160100 - RB22 Angle Barrier - Red	H800 x W680 x D500	12
RBSS160110 - RB22 Angle Barrier - Red	H800 x W680x D500	12

Angle section single unit



Linked angled sections



End stop section





Crash test summary

The RB22 barrier is designed to bring a vehicle to a controlled stop. The strength of the barrier was fully tested by TRL and achieved the following British Standard: BS EN1317 – NI 50 MPH.

The RB22 was tested under these specific conditions:

- Impact angle: 20.0°
- Vehicle mass: 1,500 kg



Initial point of impact



Crash Test Summary

Vehicle:

- Velocity and angle values were within tolerance limits
- The vehicle did not breach the device
- The vehicle did not leave the permitted CEN box
- The vehicle did not roll over within the test area
- No part of the vehicle was detached

Device:

- No part of the barrier penetrated the interior of the vehicle
- No part of the barrier was ejected

Degree of deflection at point of highest force

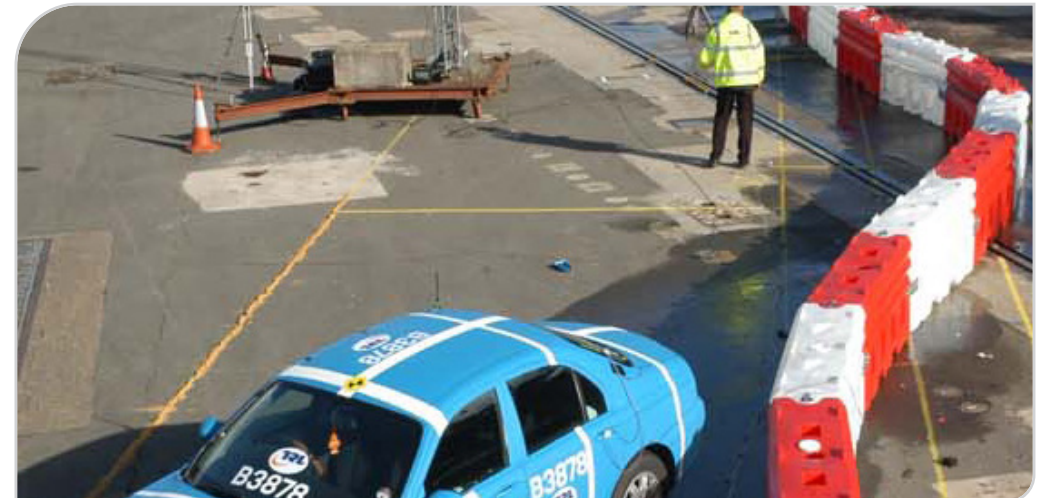



Wind load test summary

The RB22 Barrier has been rigorously tested within the MIRA wind tunnel and achieved multiple 'Class A' passes.

The 600kg stability of these water-filled barriers is unsurpassed by any other base (that can be installed without specialist equipment).

On its own, the RB22 can withstand speeds of up to 78 mph. The level of wind resistance offered by this temporary solution depends on the level of mesh you incorporate into the system.

You can adjust the level of mesh and solid panel hoarding you use, according to the different wind load speeds and requirements of your site.

The MIRA Class passes, and the wind resistance speeds achieved for each panel is displayed here.

1 RB22 Barrier Single Unit

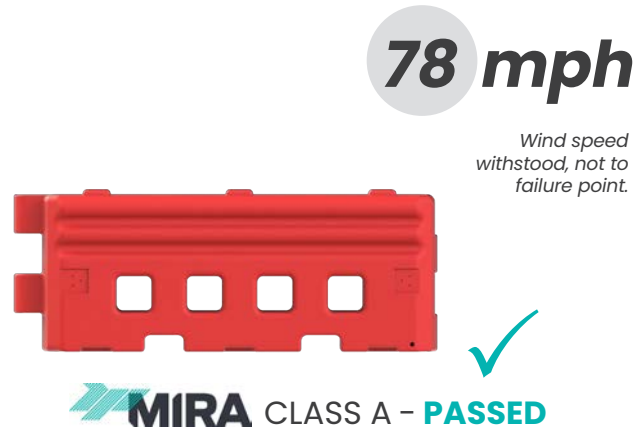

2 RB22 Barrier + Mesh Fence Panel

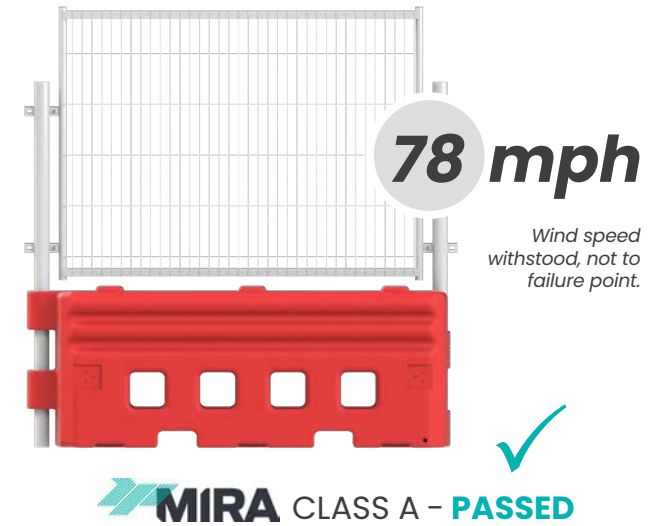

3 RB22 Barrier + Half Hoarding, Half Mesh Panel

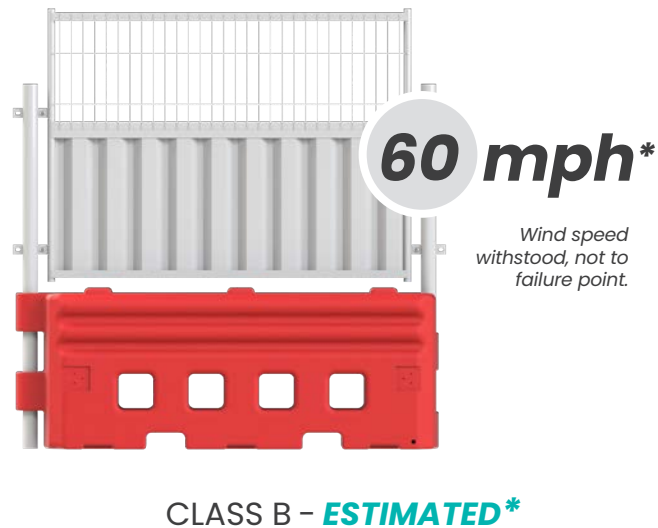

4 RB22 Barrier + Hoarding Panel





1

As viewed from trailer rear

Load from side
.....>
Stack as shown
for trailer length

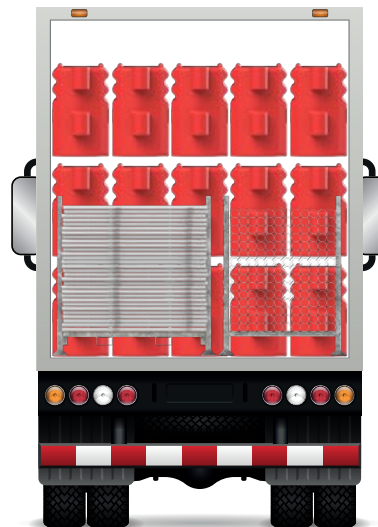

2



Stacking & packing guide

Despite weighing a colossal 600kg when filled, the barriers weigh 60kg when empty.

The illustration on the right shows how these barriers can be loaded and stacked on a lorry.

A total of 90 RB22 Barriers, or 60 RB22s and 60 panels can fit on a single artic lorry.

The diagram below demonstrates the correct loading formation for barriers and mesh fence panels.

60 RB22 barriers

60 mesh fence panels

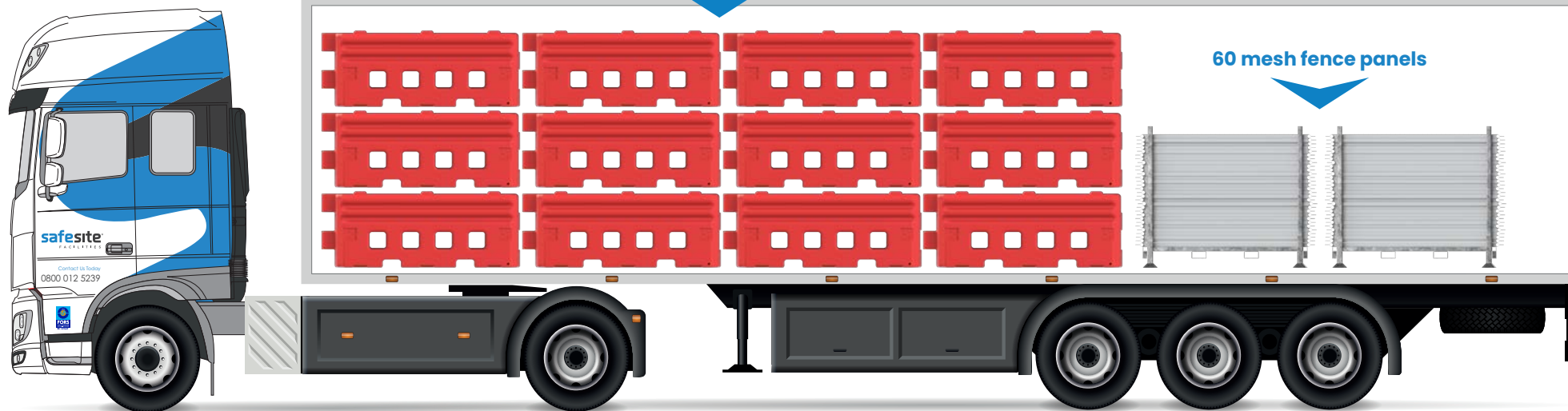



Technical Details

RB22 Barrier



Insertion points for connection pin or connecting post for mesh fence / hoarding panel poles

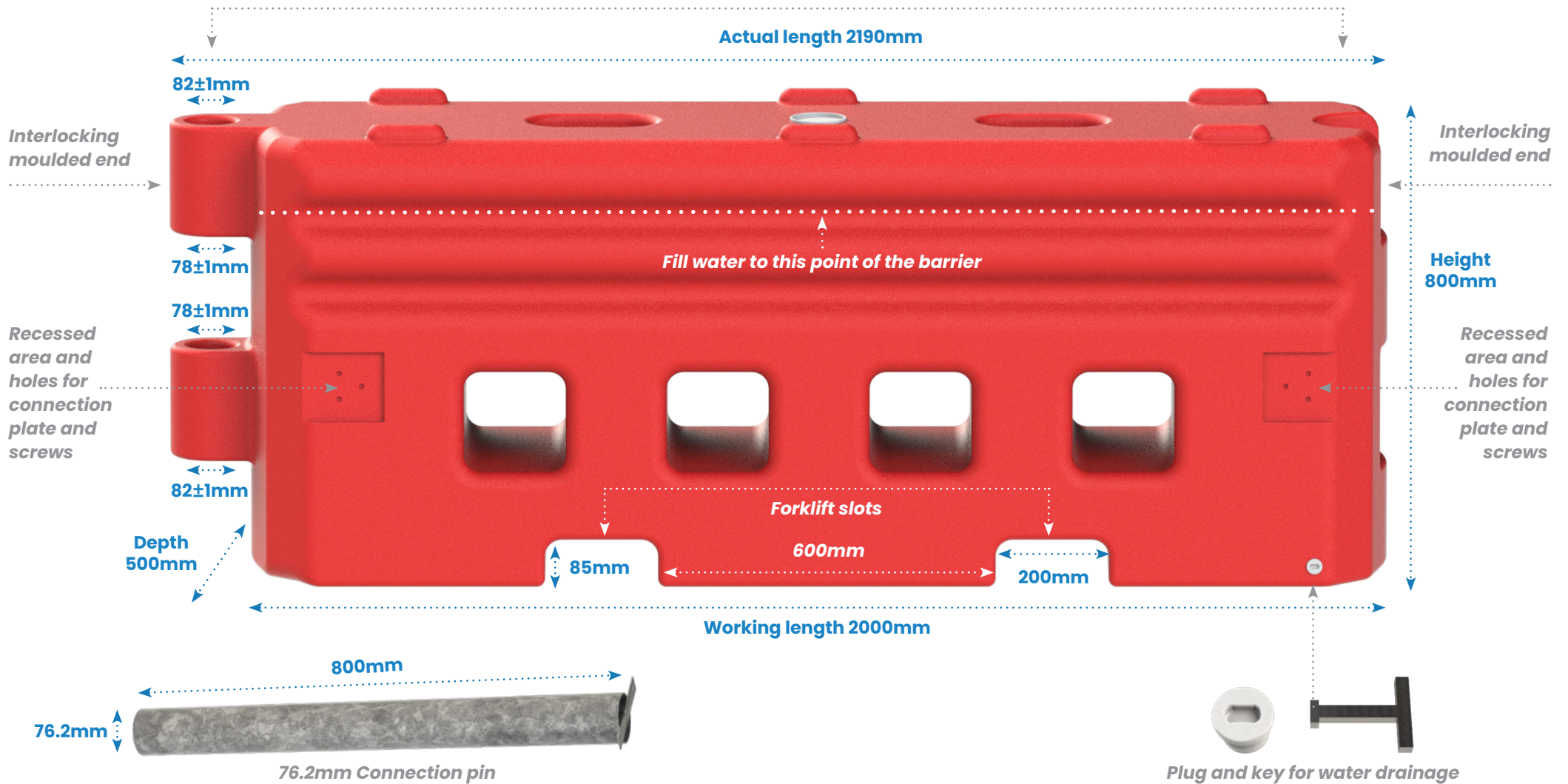



Technical Details

Fencing with Pedestrian Gate

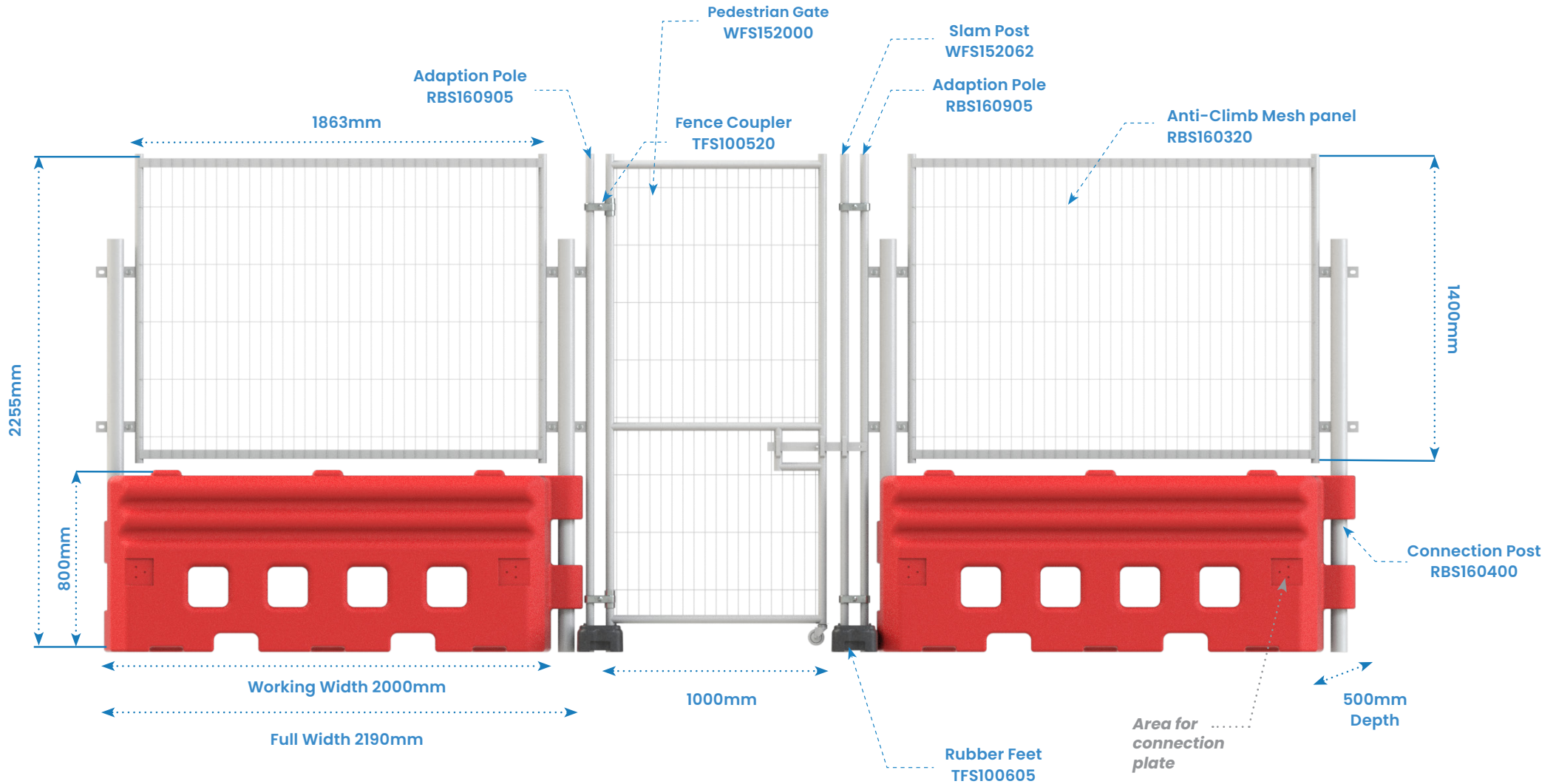



Technical Details

Fencing with Vehicle Gate

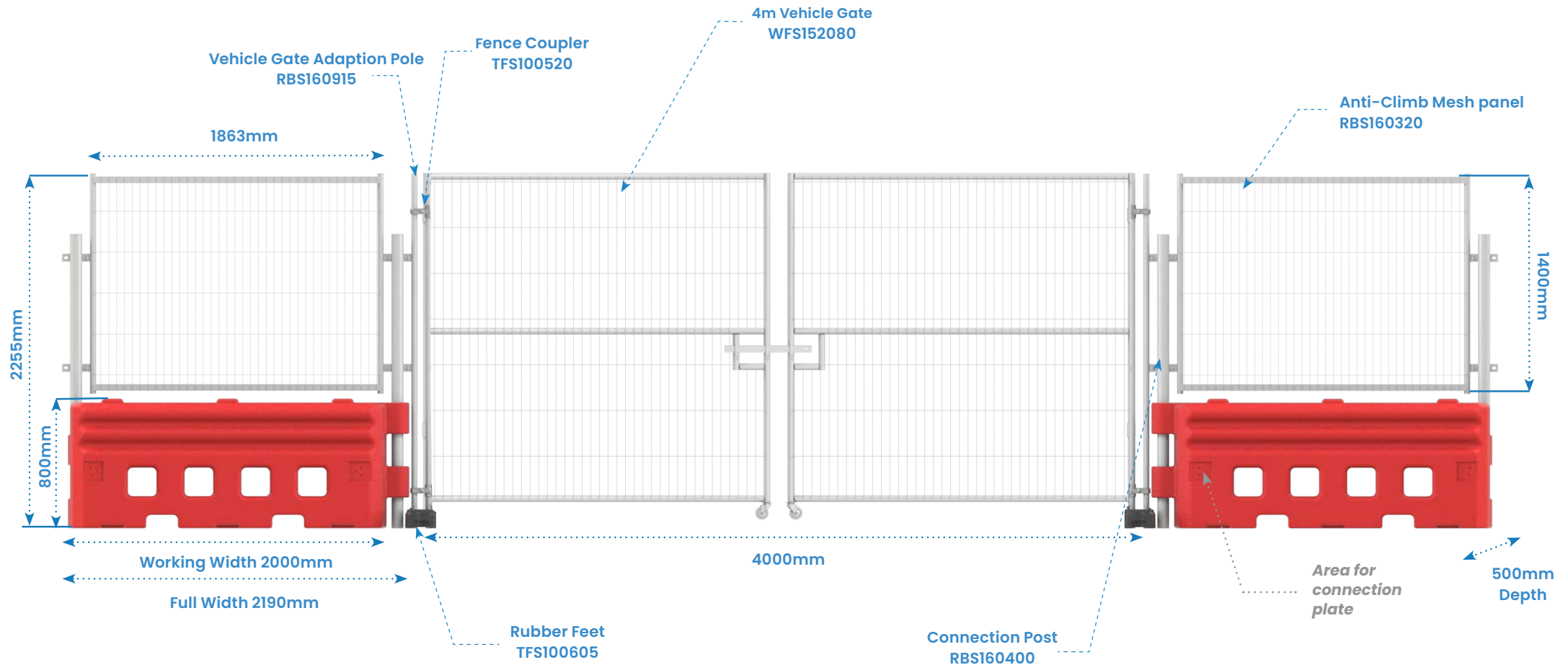



Installation parts

RB22 Water Filled Barrier - Measurements in mm

Please see below pictures and quantities of additional parts you will receive with each RB22 Barrier. The parts below are an essential safety requirement when installing the RB22 correctly.

Standard part

- 1 **Connection pin**
RBSS160250
Quantity: 1



Size (mm)	Weight (kg)
W800 x D76.2	3.2

Standard part

- 2 **M6 x 16mm GR8.8 HEX connection pin lock down screw**
Quantity: 1



Size (mm)	Weight (kg)
W16 x D6	0.74

Standard part

- 3 **Metal side plates**
RBSS160200
Quantity: 2



Size (mm)	Weight (kg)
H110 x W450 x D4	0.74

Standard part

- 4 **M12 x 25mm side plate screws**
Quantity: 12



Size (mm)	Weight (kg)
W25 x D12	0.525

Standard part

- 5 **Drainage plug per barrier**
Key in total
Quantity: 1



Accessory part

- 1 **Fencing / hoarding connection posts for connecting one panel unit**
RBS160400
Quantity: 2



Size (mm)	Weight (kg)
H1870 x D76.2	9

Accessory part

- 2 **M10 x 40mm bolts & 8 washers for securing one panel unit**
Quantity: 4



Size (mm)	Weight (kg)
W40 x D10	0.453

Accessory part

- 3 **Fence or hoarding panel per barrier with fixings listed**
RBSS160300 / RBSS160320
Quantity: 1



Size (mm)	Weight (kg)
H1400 x W1860 x D41	19

Accessory part

- 4 **Half mesh half hoarding panel**
RBS160340
Quantity: 1



Size (mm)	Weight (kg)
H1400 x W1860 x D41	19

Accessory part

- 5 **Mesh extension**
RBS160360
Quantity: 1

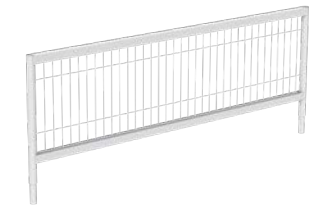

Size (mm)	Weight (kg)
H620 x W1860 x D41	19